

---

## Risk Management Model in an Ecological Storage Facility

---

Submitted 21/08/20, 1<sup>st</sup> revision 12/09/20, 2<sup>nd</sup> revision 25/10/20, accepted 11/11/20

Ewa Kulińska<sup>1</sup>, Julia Giera<sup>2</sup>

**Abstract:**

**Purpose:** The aim of the article is to develop a risk management model in an ecological storage facility.

**Design/Methodology/Approach:** The research methodology used is the ICOM cube and the BPMN method, which give the opportunity to present elements enabling risk management in a warehouse facility using environmental principles.

**Findings:** Implementation risk management model in an ecological storage facility enables sustainable development of the company, maintaining appropriate quality standards of the services provided and protection the surrounding environment.

**Practical Implications:** The subject of ecology and risk factor management in warehouse management is an inherent challenge of logistics warehouse facilities. The combination of these two aspects is important for sustainable development in warehouse management. The presented models of risk management in warehouse management make it possible to reduce the occurrence of disruptions and protect the natural environment.

**Originality/value:** The developed risk management model in an ecological storage facility enables the implementation of risk management procedures with sustainable development, which is an important aspect in the modern world. The implementation of the model by the examined entities will not only reduce the occurrence of risk factors, but also protect the natural environment. The combination of these two elements shows a new aspect of risk management in logistics companies.

**Keywords:** Ecology, warehouse management, ICOM cube, BPMN method.

**JEL classification:** G32, Q01, Q57.

**Paper Type:** Research study.

**Acknowledgment:** Research financed from the NCN research project no. UMO-2012/05 / B / HS4 / 04139.

---

<sup>1</sup>Faculty of Production Engineering and Logistics, Opole University of Technology, Opole, Poland, [e.kulinska@po.edu.pl](mailto:e.kulinska@po.edu.pl);

<sup>2</sup>Faculty of Production Engineering and Logistics, Opole University of Technology, Opole, Poland, [j.giera@doktorant.po.edu.pl](mailto:j.giera@doktorant.po.edu.pl);

## **1. Introduction**

In recent years, the topic of ecology has become an inseparable element in human life. The topic of sustainable development is particularly important for logistics areas. Society is responsible for protecting the environment, and the logistics industry is an integral part of human activity. Risk management in warehouse management enables entities to perform warehouse tasks without interruption. Combining risk management elements and an ecological warehouse allows meeting the supply chain links' requirements cooperating with the warehouse facility.

The supply chain in which storage companies belong also puts pressure on storage entities to protect the environment properly. The article aims to develop a risk management model in an ecological storage facility.

The research methodology used is the ICOM cube and the BPMN method, which enable the identification and presentation of elements enabling risk management in a warehouse facility by applying ecology principles. The implementation of sustainable development in the warehouse process operation will significantly affect the natural environment, maintaining appropriate risk management methods, and bringing warehouse companies many benefits in terms of financial and resource savings.

## **2. Ecological Risk in Warehouse Management**

The task of warehouse management is the integrated flow of movable goods, from suppliers to final recipients. The main goal is to ensure that potential consumers can buy goods and maintain the production process's continuity through constant access to raw materials and components. The warehouse management task is stabilization in meeting the needs of production organizations and consumers (Kulińska and Rut, 2017). Risk management should take place in a targeted and planned. Actions taken to counteract the occurrence of risk factors should be systematic and long-term. The integration of all activities for comprehensive organization management is also a necessary element (Kulińska, 2011).

The deepening globalization means that logistics facilities are regularly exposed to risk. For this reason, it is necessary to manage the risk that allows the stabilization of costs in the market (Thlon, 2012).

The need to use storage services by manufacturing companies is due to the difference in the volume of demand and supply, elimination of shortages of goods, economic reasons, and supplying the production process (Figurski, 2012). Warehouse management has become a key component of the supply chain. In addition to transport, it is a leading element of any supply chain with movable goods.

---

Warehouses are an essential element supporting products' flow through the supply chain (Ripkema, Rossi, and Van der Vorst, 2014; Kauf and Bruska, 2012). Provision of warehouse services and transport are the guiding links of the supply chain, where there are goods (Kleindorfer and Saad, 2005).

Ecology has become an inherent element in all of us and relates to logistics areas, in particular warehouse management. The concept of environmental protection was created to raise the level of ecological awareness of society. Economic criteria' subordination also influences it in social and environmental terms (Wiktorowska-Jasik, 2011). Ecology is implementing optimal activities for collecting and disposal of waste, directing them for utilization, or waste disposal that is not harmful to the natural environment and humanity (Michniewska, 2006).

Regulations law characterize the need for appropriate management of the generated waste in warehouse management. Also, all the supply chain links put pressure on each other to properly protect the environment by providing logistics services (Richards, 2016).

### **3. Research Object**

The characteristics of the implementation of ecology principles in warehouse facilities were determined based on a logistic audit. The surveyed entities are enterprises providing warehouse services in Poland. The number of research facilities is 12 storage companies. All warehouse facilities meet the following requirements:

- mechanized warehouses,
- high storage buildings,
- facilities with between 10,000 and 25,000 pallet spaces,
- warehouses use bar codes as a technique for automatic identification of goods.

The logistic audit carried out included data usage characteristics, statistical data on the occurrence of risk over time, and enterprises' ecological elements.

### **4. Ecological Risk Factors Management**

There are several types of risk factors in warehouse management. The interference was divided into two groups:

1. Infrastructure and warehouse equipment,
2. Model of warehouse management.

Table 2 was developed based on the logistic audit data and managing risk factors in ecological terms.

**Table 2. Environmental risk management**

Risk factors	Managing risk factors in terms of eco-logistics
<b>Warehouse infrastructure and equipment</b>	
<p>– warehouse location</p>	<p>Warehouse location is a key element in the flow of goods in the supply chain. The building's environment has a significant impact on the natural environment. Most of the warehouses of the surveyed entities are located on the outskirts of cities, around agricultural fields and forest area. Warehouse operation should not disturb the functioning of animals around the warehouse facility, therefore an important element is to reduce air pollution and noise levels.</p>
<p>– warehouse equipment</p>	<p>Elements of a warehouse facility implementing environmental principles:</p> <ul style="list-style-type: none"> <li>- the use of energy-saving lighting systems that will be equipped with motion sensors. Installing lamps in the right places and at the right height, remembering about their proper intensity in order to maximize the use of light from the lamp and reach the largest possible storage area.</li> </ul> <p>The office part uses a large number of windows. This will enable the influx of daylight. Install skylights in the warehouse hall, remembering to clean them regularly to increase the availability of daylight.</p> <ul style="list-style-type: none"> <li>- obtaining energy from renewable energy sources, e.g. solar panels, wind farms and heat pumps. Turn off all devices that do not need to remain turned on after completing the task.</li> <li>- heating water from renewable energy sources. The amount of hot water should be adjusted to the number of people working in the warehouse.</li> <li>- collecting waste water into tanks and collecting water from tanks absorbing humidity from the air. The accumulated water can be used for the following: cleaning the warehouse floor or watering the grass around the warehouse.</li> <li>- controlling the air heating system. The use of separate thermostats for office areas and warehouses with temperature determination.</li> </ul> <p>Determining the heating time of the building. In the event of storage operations not working at night in some rooms, the temperature may be lower. When using air conditioning, remember to close the windows in the rooms and turn off the device before leaving work.</p> <ul style="list-style-type: none"> <li>- use of natural ventilation for the office space. Systematic window opening.</li> <li>- closing rooms to reduce air circulation between the warehouse hall and the office space, where there is a need for temperature differences.</li> <li>- ramp tightness is very important in order to have a constant room temperature and humidity level. Invest in sealing sluices (sealing sleeves) or tunnel sluices that limit outside air access to the storage area.</li> </ul> <p>The following are ecological principles that should be implemented into storage machinery and equipment:</p> <ul style="list-style-type: none"> <li>- possessing modern propulsion technologies in the forklift fleet. They extend the life of the devices by using less energy.</li> <li>- purchase of the right amount of batteries for scanners and forklifts. Buying the quantities required, with a minimum amount of battery reserve. One-time use of the battery starts the product life cycle, which means that the batteries need to be changed more often, despite the fact that they are not fully exploited. Transfer of used batteries to appropriate points, e.g. Municipal Waste Collection Point. Pay attention to the</li> </ul>

	correct charging of the battery, e.g. not allowing the product to completely discharge. This factor means in a way that it extends the life of the product.
– equipment failure	Systematic checking of the technical condition of equipment used in warehouse management. Machines and devices that are not suitable for further operation should be sent to the Municipal Selective Waste Collection Point. In particular, constant monitoring of the technical condition of storage racks is important. If the rack is damaged, it must be repaired immediately. A damaged storage rack is a real threat to the warehouse operator and stored resources that may be destroyed.
– no division of the warehouse into fast and slow rotation materials	Possibility of storing expired items not suitable for further sale. Foodstuffs can be handed over for utilization to farms in the form of animal feed. Greater control over stock levels in order to prevent waste from the finished product.
– unsuitable area in warehouse	Improper equipment of the warehouse with equipment for storing warehouse goods creates a greater probability of damage to the goods. In particular, goods that are too close together. It is also important to create an appropriate zone for storing warehouse waste and an area for selecting waste generated in the warehouse.
<b>Warehouse management model</b>	
– incorrect flow of information between warehouse employees – incorrect flow of information between supply chain actors	The correct flow of information is a key factor in an efficient warehouse process and the entire supply chain. With the emergence of misunderstandings, there is a need to increase the flow of information in the form of emails and paper documentation. All documentation that does not require archiving should be sent for recycling. Keep printing emails to a minimum.
– no material classification, – no detailed data on individual stocks, – material quality control system – inventory optimization only for one criterion.	These risk factors share one common effect: the finished product becomes waste. Lack of information on stored products, quality control of goods and the application of appropriate criteria for optimizing inventories in order to release goods within a specified period may result in the fact that stored inventories cannot be sent to the next link in the supply chain, and will have to be transferred to utilization.

*Source: Own study.*

The table above indicates the elements that warehouse companies should implement to have a green facility while maintaining risk management principles. The element enabling the implementation of the presented elements into the warehouse facility is presenting the necessary links in the supply chain that enable the warehouse facility's organization ecologically.

The research methodology used is the ICOM cube for the ecological storage process (Figure 1). Presents input and output elements in warehouse management. It also shows the control mechanisms as well as elements supporting the ecological activity of the warehouse.

Figure 1. Cube ICOM ecological storage facility

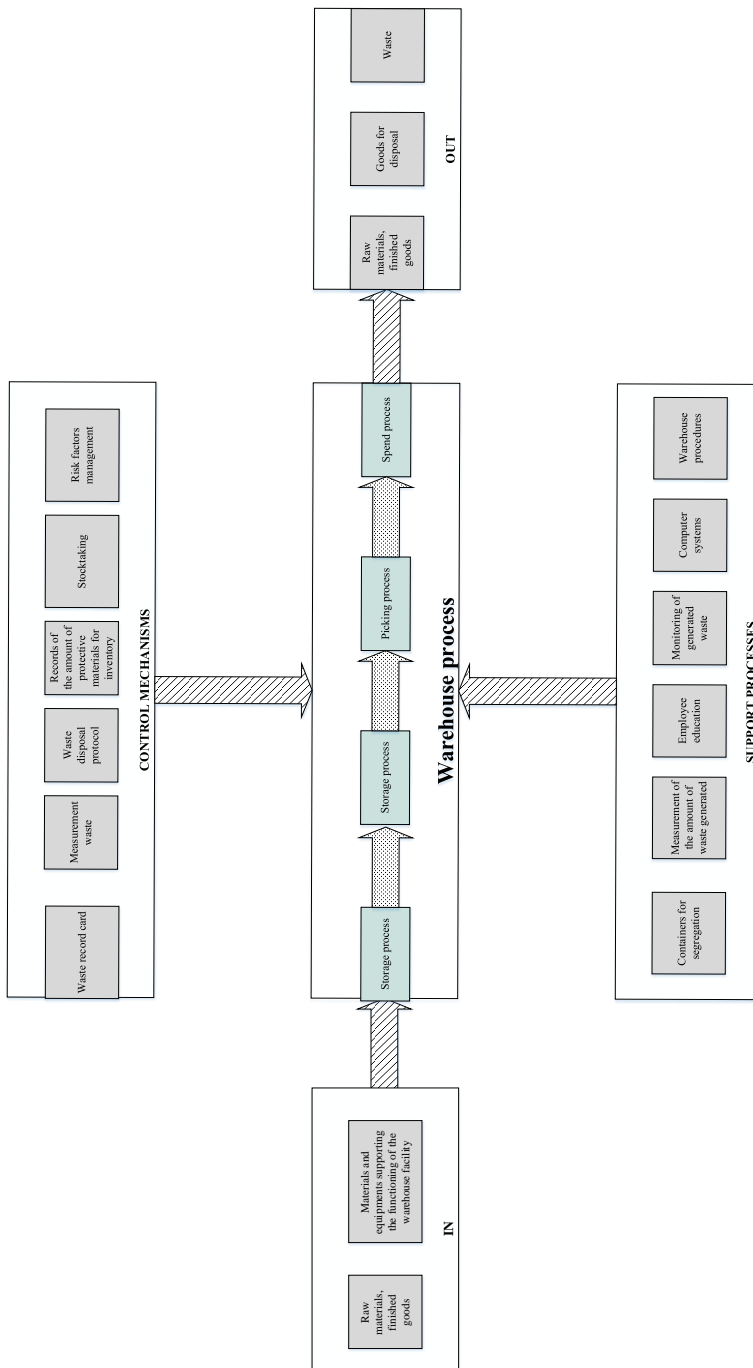

Source: Own study.

---

An important element is identification, analysis, measurement, and assessment of risk factors. The collected data form the basis for developing the model, which aims to reduce risk factors. The presented input and output elements in the warehouse facility show the problem's scale, which is the generation of waste and goods for disposal. The complete elimination of waste in mechanized warehouses is impossible, which is why control and storage support mechanisms are so important.

The waste record card, waste measurement, and records of the number of materials used to protect the stored stock allow the entities examined to determine the scale of production of unnecessary waste. Supporting procedures show ways to control risk management and determine parameters related to the functioning of the facility. One of the elements supporting storage facilities is the definition of storage procedures and monitoring of generated waste, where the key element is the flow of information between departments in the storage facility. An extension of the ICOM cube element for the ecological storage process is Business Process Modeling Notation (BPMN). The BPMN method is used to present links between links in warehouse management. Correct communication is one of the most important elements of minimizing the likelihood of risk factors in a warehouse facility.

Below is the BPMN diagram for the ecological model of warehouse management (Figure 2). This diagram is presented indicating 4 areas affecting the ecological management of risk factors:

- Risk management department,
- Ecology department,
- Warehouse proces,
- Finance department.

The application of the BPMN method enabled determining the location of individual links in the warehouse management necessary for the facility's proper functioning. The entry element is the receipt of goods in the warehouse, and the final element is the utilization of waste generated in the warehouse. The diagram contains the elements that individual departments perform in the warehouse facility. All stages of the warehouse process are shown along with the necessary elements, thanks to which it is possible to combine the management of risk factors and compliance with environmental principles.

In an environmentally-friendly storage facility, the risk management model presents the procedure that research entities can implement in their enterprises. It is a utilitarian model to which specific features of an individual enterprise can be adapted while maintaining the two most important aspects: minimizing the likelihood of risk factors by using risk management methods and applying an ecological storage facility's principles, bearing in mind sustainable development in the modern world.

Figure 1. Risk management model in an ecological storage facility

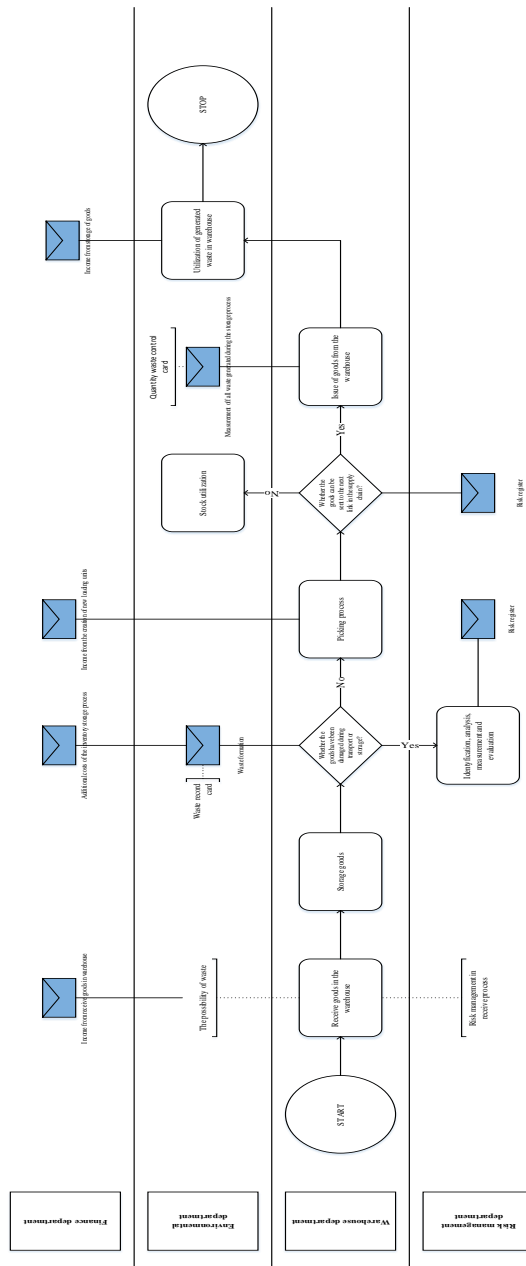

Source: Own study.

## 5. Summary

Contemporary management of risk factors in warehouse management can relate to



leveling disturbances in warehouse facilities, and in the supply chain, it should also cover sustainable development by implementing environmental principles in warehouse facilities.

The presented ICOM cube and BPMN method showed the use of environmental principles in two aspects. The ICOM cube allowed specifying supporting elements and control procedures necessary for the systematic monitoring of existing risk factors and enabled the determination of consumed raw materials and waste generated in the entity. The BPMN method is a development of the ICOM cube, which shows the risk management model in an ecological warehouse facility, presenting one of the most important aspects in the proper functioning of logistics companies: the flow of information.

Implementing appropriate procedures by implementing a risk management model in an ecological storage facility will enable compliance with risk management principles in the logistics warehouse and sustainable use of resources. These two links will enable research entities to achieve real financial and resource savings, crucial for an ecological supply chain.

## References:

- Figurowski, J. 2012. *Ekonomika logistyki, cz. 3, Gospodarka magazynowa*. Wyd. Wojskowa Akademia Techniczna, Warszawa.
- Kauf, S., Bruska, A. 2011. System magazynowy jako ogniwo łańcucha dostaw w obsłudze rynków lokalnych. *Gospodarka Materiałowa i Logistyka*, 3.
- Kleindorfer, P.R., Saad, G.H. 2005. *Managing Disruption Risks in Supply Chains*. Production and Operations Management.
- Kulińska, E. 2011. Aksjologiczny wymiar zarządzania ryzykiem procesów logistycznych. *Modele i eksperymenty ekonomiczne*, Oficyna Wydawnicza Politechniki Opolskiej, Opole.
- Kulińska, E. 2014. Importance of costs of risks in material management, 6(1).
- Kulińska, E., Rut. J. 2017. Optimization of the material and information streams flow in the manufacturing company. *Marketing i Rynek*, 7.
- Michniewska, K. 2006. Nowe trendy w logistyce: logistyka odzysku, a ekologia. *Logistyka*, 1.
- Richards, G. 2016. *Zarządzanie logistyką magazynową*, PWN, Warszawa.
- Ripkema, W.A., Rossi, R., Van der Vorst, J.G.A.J. 2014. Effective sourcing strategies for perishable product supply chains. *International Journal of Physical Distribution & Logistics Management*, 44(6).
- Thlon, M. 2012. *Zarządzanie ryzykiem operacyjnym przedsiębiorstwa. Metoda szacowania ryzyka deltaEVT*, Wyd. Uniwersytetu Ekonomicznego w Krakowie, Kraków.
- Wiktorowska-Jasik, A. 2011. Ekologia - nakaz ustawowy, moda czy wyzwanie dla przedsiębiorstw XXI wieku. *Logistyka*, 6.